

Machine  
**WINNER**  
台灣威諾斯漢機床 CE



an

**高速鑽孔·攻牙機**

**WORLD CLASS QUALITY**

[www.winnerstech.com.tw](http://www.winnerstech.com.tw)



## 高速鑽孔·攻牙機

### TAP-510 AP-500

#### HIGH SPEED TAPPING & DRILLING CENTER

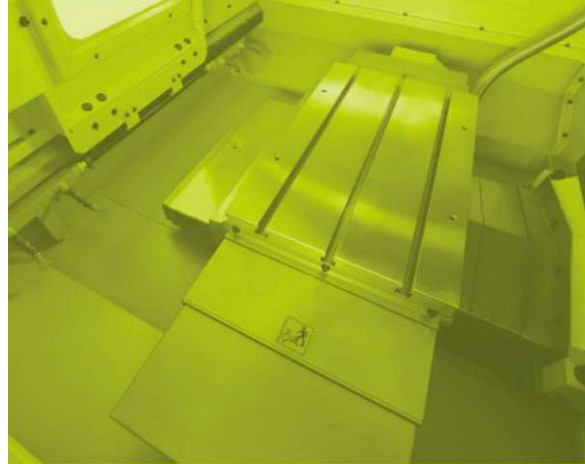

HIGH

#### 機台特色

- ▶ **高速直結式主軸**
  - 直結式主軸傳動系統
  - 主軸轉速: 10000rpm (標準) ~ 20000rpm (選配)
- ▶ **高速換刀機構**
  - 凸輪傘型刀庫(轉塔式) / 分割式機械快速換刀
  - 刀庫備有14T (標準) 或 21T (選配)
  - 換刀時間 1.8秒(刀對刀)
- ▶ **高剛性結構設計**
  - 提供足夠的穩定性, 適用於高速鑽孔、攻牙並離銑加工。
- ▶ **高速進給**
  - 快速進給48/min.

#### Features:

- ▶ **HIGH-SPEED DIRECT-DRIVE SPINDLE**
  - High speed spindle direct driving transmission
  - Max. spindle speed : 12000rpm (STD.) ~20000rpm (OPT.)
- ▶ **HIGH-SPEED ATC**
  - Turret type ATC featured with indexing mechanism
  - Turret type ATC provides 14T (standard) & 21T (option) as alternative.
  - Fast tool changing time 1.8 sec. (T to T)
- ▶ **HIGH RIGIDITY STRUTURE DESIG**
  - Provides the strong enough reliability meet for high speed drilling tapping & milling works.
- ▶ **HIGH-SPEED FEED**
  - Max. rapid infeed speed at 48M/min.



四軸加工應用

Machine  
**WINNER**  
台灣威諾斯漢

## H SPEED TAPPING & DRILLING CENTER



### 加工領域

- 汽車部件加工
- 3C 產品加工
- 去毛邊 / 倒角加工
- 小孔徑鑽孔加工

### Applications

- Auto parts, light alloy formed parts machining
- IT components & 3C industries processing applications
- Super finishing & round chamfering
- Small hole drilling performance being decreased to 0.1mm



三軸線性滑軌



**APC-500** PALLET CHANGER TYPE - HIGH SPEED TAPPING/DRILLING MACHINES

**APC-500** 交換工作台



**TAP-510**

皮帶式主軸

Belt drive spindle

標準 (STD) : 10000RPM

選配 (OPT) : 12000RPM



**AP-500**

直結式主軸

Direct drive spindle

標準 (STD) : 12000RPM

選配 (OPT) : 20000RPM

追求卓越，贏得尊敬

規格 SPECIFICATIONS			Unit	TAP-510	AP-500	
工作臺	Work Table	尺寸(長*寬)	Working table size	mm	600×360	650×400
		T型槽	T slots	mm	18×3×100	14×3×125
		最大負荷	Max. table load	kg	200	200
行程	Travel	X軸行程	X axis travel	mm	510	500
		Y軸行程	Y axis travel	mm	350	400
		Z軸行程	Z axis travel	mm	300	300
		主軸鼻端至工作臺面的距離	Spindle nose to table surface	mm	130-430	130-430 (可加高)
		主軸中心至立柱軌道面距離	Spindle center to column	mm	450	410
主軸系統	Spindle	傳動方式	Transimmission		皮帶式/Belt type	直結式/Direct driving
		主軸轉速	Spindle speed	rpm	10000	12000~20000
		主軸馬達	Spindle motor	kw	3.75/5.5	2.0/3.75
		X/Y/Z軸馬達(發那科)	X-Y-Z motor output (Fanuc)	kw	1.2/1.2/1.8	1.2/1.2/1.8
		X/Y/Z軸馬達(三菱)	X-Y-Z motor output (Mitsubishi)	kw	1.5/1.5/2.0	1.5/1.5/2.0
進給系統	Feed	快送速度(X/Y/Z)	Rapid feed	m/min	48/48/36	48/48/36
		最大進給速率	Cutting feed rate	M/min	10	10
自動換刀系統	ATC System	刀庫形式	ATC type		凸輪轉塔式/分割式機械快速換刀 Turret type / Indexing mechanism	
		刀柄	Spindle taper		BT-30	BT-30
		刀庫容量	Tool no.	pcs	12	14
		最大刀具長度	Max. tool length	mm	200	200
		最大刀具重量	Max. tool weight	kg	3	3
空壓源	Air pressure	換刀時間	Tool to tool time	sec	1.8	1.6
		空壓源	Air pressure requirement	kg/cm <sup>2</sup>	6	6
機械規格	Machine's Diameter	占地面積(LxW)	Floor occupation	mm	1950×2000	2230×1850
		機械重量	Machine weights	kg	2100	2300



台灣威諾斯漢機床股份有限公司 TAIWAN WINNERSTECH MACHINERY CO., LTD.

台中市大雅區中正路花眉巷23-7號  
TEL : 886 4 25652092 FAX : 886 4 25652391 E-mail : info@winnerstech.com.tw winner.shad@msa.hinet.net

23-7, Huamei Lane., Zhong Jheng Rd., Daya Dist., Taichung City 428, Taiwan  
winner.shad@msa.hinet.net

www.winnerstech.com.tw  
www.winner.tw.cn

大陸廠：南京穎元科技(股)公司

China Factory: Nanjing Yingyuan Technology Co., Ltd.

南京市六合區瓜埠鎮丰原路1-2號  
TEL : 025 57633337 . 57633338 . 57199009 FAX : 025 57632338

No. 1-2, Fong-Yuan Rd., Guabu Town, Lio-Heh Area, Nanjing City, China

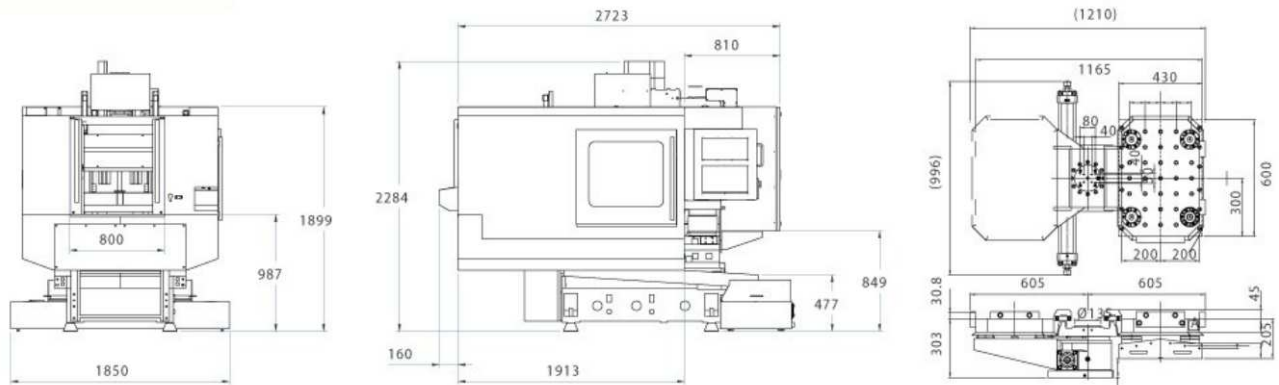

AP-500

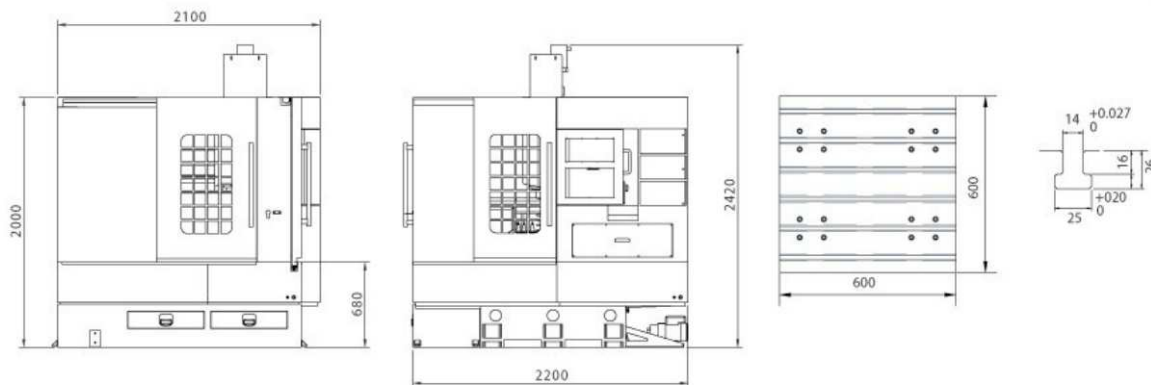

APC-500

備註：所有規格與設計，公司保有最終修改之權利，若有變更，恕不另行各別通知。  
All specifications & design are subject to change without prior notice.